

058120

Items		Normal	Remark
Capacity	Typ.	#DIV/0!	0.2CmA(9mA) discharge
	Min.	45mAh	
Voltage		3.7V	0.2CmA (440mA) average voltage
Internal Resistance		≤60mΩ	
Power Off Voltage		2.75V	
Charging Current		45mA	Standard charging
Maximum Charging Voltage		4.25V	
Charging Time		about 2.5h	45mA charging
Maximum Charging Current		67.5mA	1.5CmA
Maximum Discharge Current		90mA	2.0CmA
Approximate Weight		#DIV/0!	
Operating Temperature and Humidity	Charging	0~+45°C	
	Discharge	-20~+60°C	
Storage Temperature	<1 month	-20~+45°C	Recommended storage temperature during transportation is at 23°C
	>6 months	-20~+35°C	

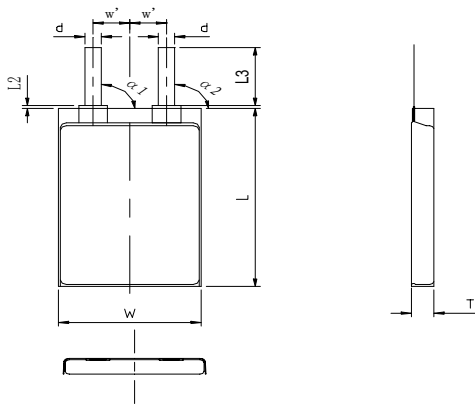

Demension	Unit
T (MAX)	0.5mm
W (MAX)	81.5mm
L (MAX)	20.5mm
L2	1±0.5mm
L3	9±1mm
W'	5±1mm
d	5mm
a1	90±5°
a2	90±5°

T: Thickness
W: Width
L: Length

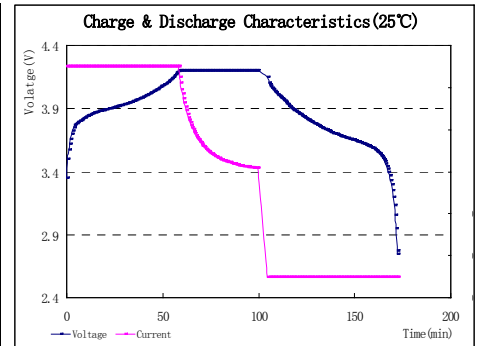

Figure 1 Charge & Discharge Characteristic

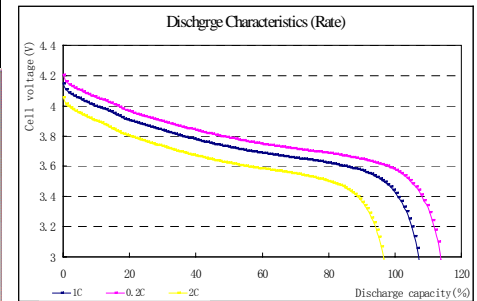

Figure 2 Discharge Characteristic

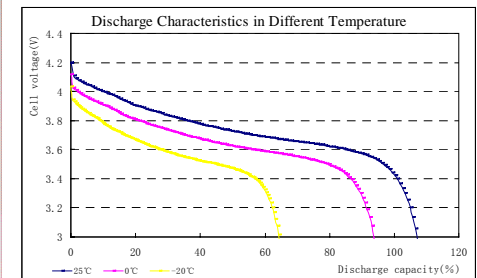

Figure 3 Discharge Characteristic in Different T

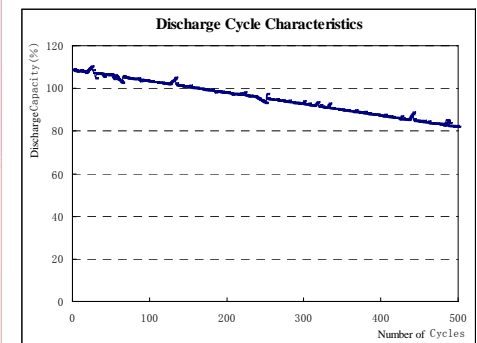

Figure 4 Discharge Cycle Characteristic